

A

B

C

D

E

F

1

2

3

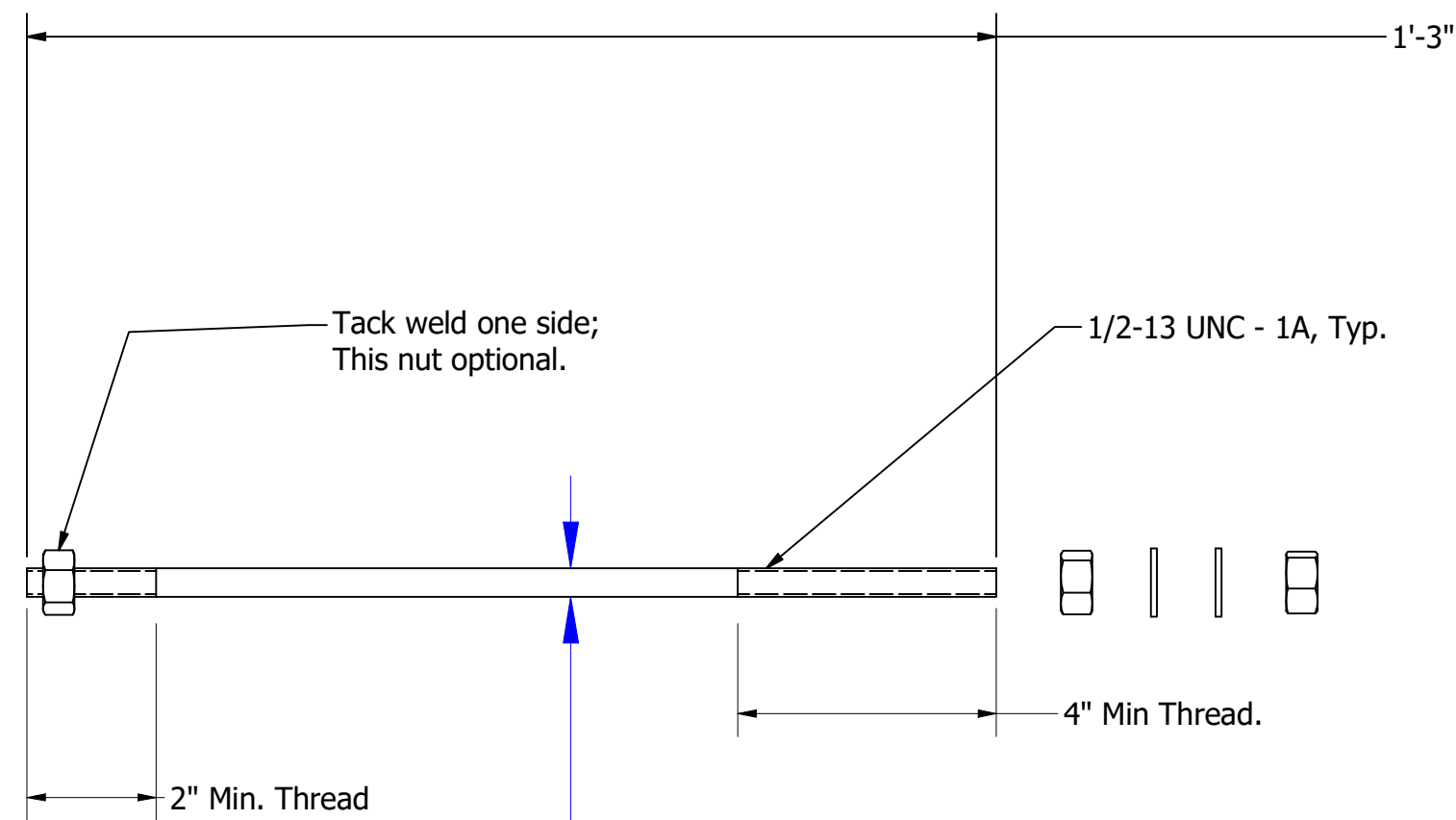

4

5

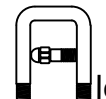

Available in the Following Grades:

- F1554 Gr. A36
- F1554 Gr. A36 Hot Dip Galv.
- 304 Stainless

UNLESS OTHERWISE SPECIFIED				DRAWN: Alan Harris		12/21/2021		 Alexander Screw Products, Inc.		8750 Pendleton Pike Indianapolis, IN 46226	
DIMENSIONS ARE IN INCHES				MATERIAL		CHECK:		TITLE:		REV.	
.X	.XX	.XXX	ANGLE	SAE 304				AS050015S			
±	±	±	± 0.5°	FINISH		ENGR:		12/21/2021			
	125 ✓			Stainless		MFG:				SCALE	
DIMENSIONING & TOLERANCING PER ASME Y14.5-2009 ALL DIMENSIONS IN INCHES [MM] BEFORE / AFTER SURFACE TREATMENT REMOVE ALL BURS AND SHARP EDGES THREADS: EXT CLASS 2A, INT 2B PROTECTIVE WRAP OR EQUIV. IDENTIFY PART ON WRAP OR EQUIV.						REVISION BY:				SIZE C DRAWING NO. Anchor Bolt Print	
				CUSTOMER:						SHEET 1 OF 1	
								WT N/A			

Anchor Bolt Print

P/N