

[1-3/4"] ANCHOR BOLT

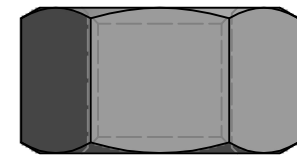

X

 1

Gr A

Gr C

DH

2H



X

 1

USS FW

F436

PLATE

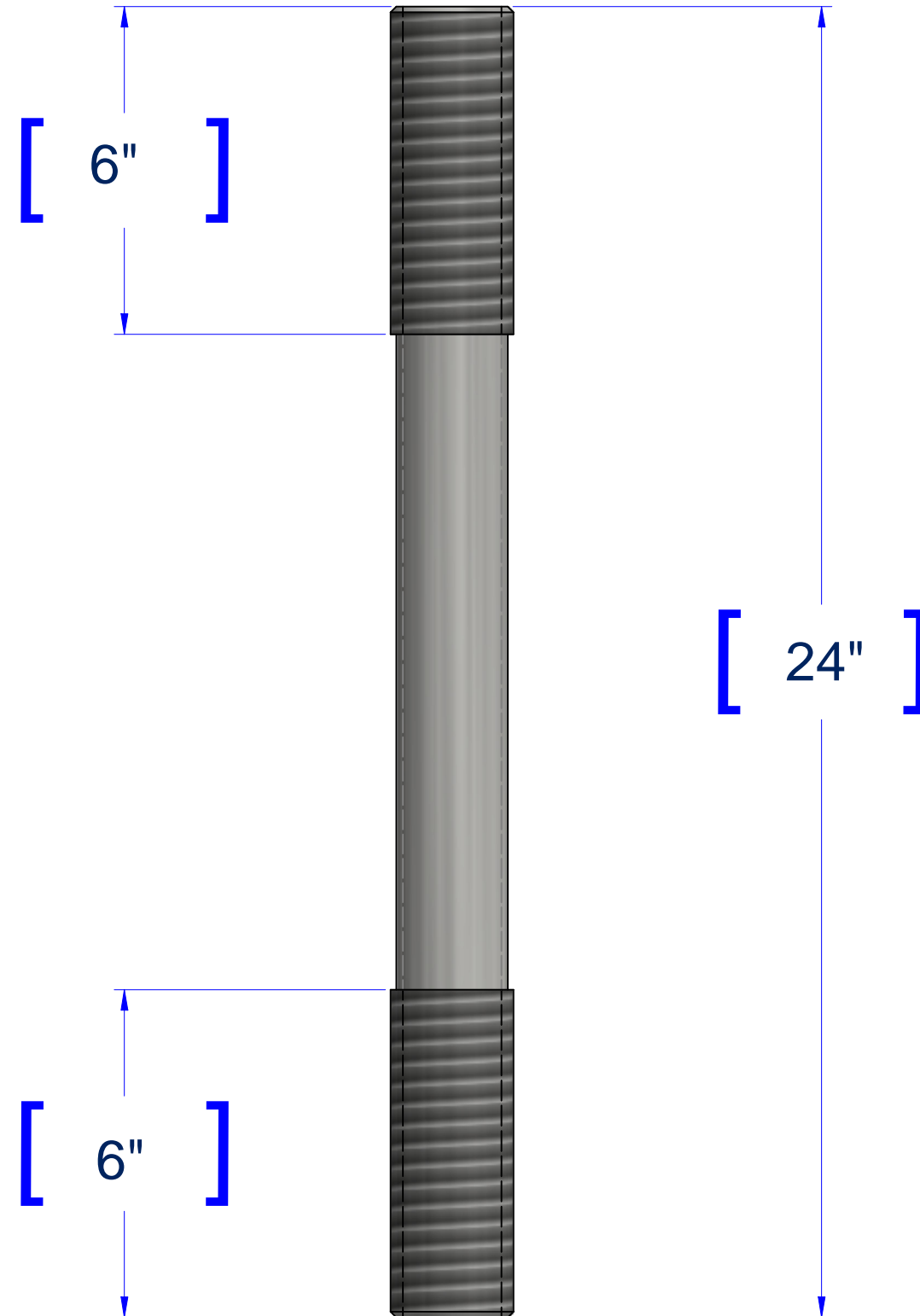

X

 1

USS FW

F436

PLATE

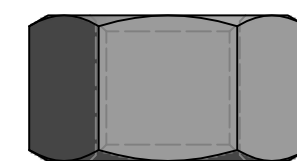

X

 1

Gr A

Gr C

DH

2H

UNLESS OTHERWISE SPECIFIED
DIMENSIONS ARE IN INCHES

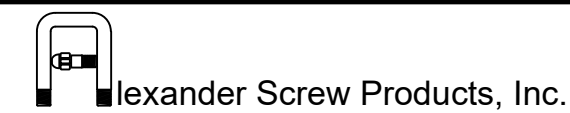

8750 Pendleton Pike
Indianapolis, IN 46226

All bolts are roll threaded from undersized material per the F1554 Standard.
Galvanized bolts shall meet F2329-11.
All Threads meet a minimum of 1A and are made from unground F1554 Hot Roll Material.

GRADE: F1554 A36
 F1554 55-S1
 F1554 105
 304 STAINLESS

PART #:

FINISH: PLAIN STEEL
 HOT DIP GALVANIZE

ROLL THREAD Ø:

THREAD SIZE:

CHOP LENGTH:

1

2

3

4

5